



## CENTRIFUGAL SIEVE SHAKERS



The main utility of the centrifugal sieve shakers is to separate different fractions of a material with an important percentage of product.

They are made of stainless steel and can be used for safety sieving to eliminate some product's impurities. This is a suitable application in industrial sectors like feeding or pharmacy with products like plastic, varnish, ceramics, etc.

Available models: **FTIC-0650** y **FTIC-0800**.

TECHNICAL CHARACTERISTICS					
<b>FTIC-0650</b>	220/380 V	50-60 Hz	690 rpm	5.83/3.37 A	1.1 Kw
<b>FTIC-0800</b>	220/380 V	50-60 Hz	850 rpm	5.83/3.37 A	1.3 Kw



### INCLUDE:

- ▶ Centrifugal sieve shaker.
- ▶ Operating instructions manual.
- ▶ CE declaration of conformity.

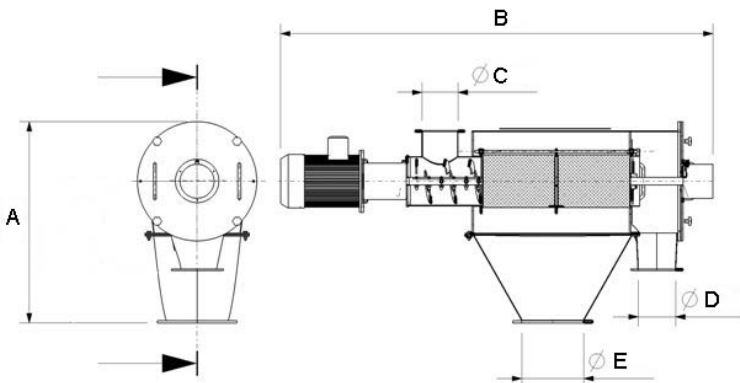

(mm)	FTIC-0650	FTIC-0800
<b>A</b>	810	950
<b>B</b>	1720	2000
<b>C</b>	Ø 140	Ø 200
<b>D</b>	Ø 150	Ø 150
<b>E</b>	Ø 250	Ø 250

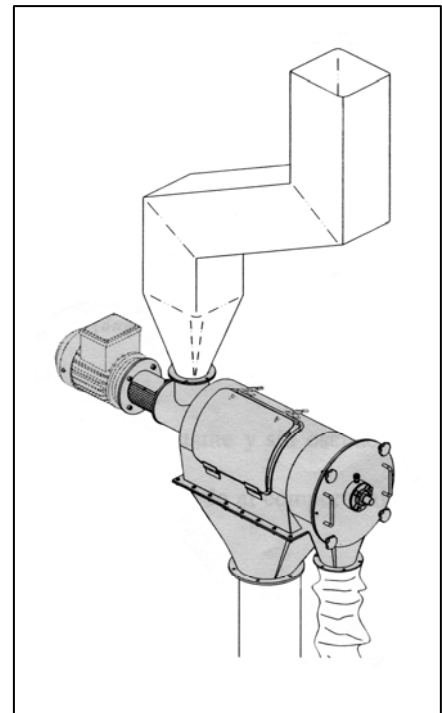

Example of installation.