



CIRCULAR SIEVE SHAKERS



These industrial machines made in stainless steel work with solid and liquid products.

They have circular bodies that facilitate the extension of sieving levels. These bodies have lateral outlets to give up the different fractions of the product.

They have an adjustable eccentric masses engine which let the product changes his behaviour on the metallic mesh. These engines make a balanced and vibration movement. In addition the bodies are isolated from the vibratory set with springs so that vibrations do not pass through the structural base.

Available models: FTI-0550, FTI-0800, FTI-1200 y FTI-1500.

TECHNICAL CHARACTERISTICS					
FTI-0550				1.73/1.0 A	0.42 kW
FTI-0800	220-230 V 380-400 V	50 Hz	1500 rpm	4.3/2.5 A	1.2 kW
FTI-1200				5.3/3.1 A	1.8 kW
FTI-1500				5.3/3.1 A	1.8 kW

INCLUDE:

- ▶ Circular sieve shaker with 1 sieving level.
- ▶ Operating instructions manual.
- ▶ CE declaration of conformity.

These machines are used in the chemical industry, feeding, pharmacy, farming, recycling, water treatment, etc., guaranteeing from 100 to 25.000 kg/h depending on the product, the mesh hole and the volume of the machine's feeding.



Liquid glue

Pepper

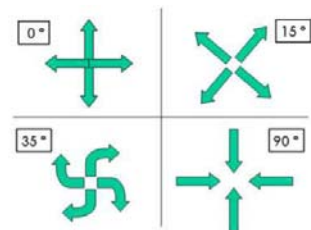

Material movement depending on the eccentric masses' engine adjustment

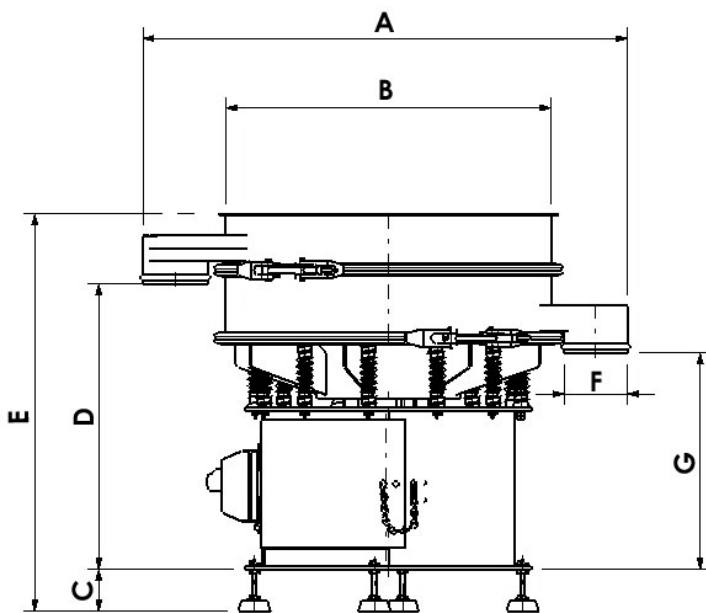

FTI-1NIVEL

(mm)	FTI-0550	FTI-0800	FTI-1200	FTI-1500
A	710	1160	1680	2096
B	544	754	1154	1491
C	90	90	90	90
D	590	662	705	840
E	755	920	1026	1140
F	100	147	196	200
G	410	501	496	600

CIRCULAR SIEVE SHAKERS

PRODUCTIVITY

PRODUCT	DENSITY	HOLE MESH (mm)	STATE PRODUCT	SIEVE SHAKER MODEL	PRODUCTION
Dust painting	1.2	0.200	Solid	FTI-0550	500 kg/h
Acrylic painting	1.2	0.080	Liquid	FTI-0800	1200 l/h
Liquid glue	1.2	0.250	Liquid	FTI-1200	1300 l/h
Detergent	1.0	5	Solid	FTI-1500	9500 kg/h
Clay	1.1	0.063	Liquid	FTI-1200	3200 l/h
Plaster	1.5	0.150	Liquid	FTI-1200	18000 l/h
Dust aluminium	1.2	0.180	Solid	FTI-0800	400 kg/h
Titanium	1.4	1	Solid	FTI-0800	550 kg/h
Pig excrements	1.1	0.100	Liquid	FTI-1200	20000 l/h
Milky serum	1.0	0.025	Liquid	FTI-1200	7000 l/h
Dust milk	0.7	0.400	Solid	FTI-0550	600 kg/h
Grain sugar	0.8	0.400	Solid	FTI-0800	7200 kg/h
Pepper	0.5	0.900	Solid	FTI-1200	2000 kg/h
Orange juice	1.0	5	Liquid	FTI-0800	2500 l/h



Dehydrated tomato



Paper and plastic recycled



Grain



Fruits concentrated juice

OPTIONAL RELATED PRODUCTS

- Stainless steel cover.

It is used for solid and liquid products that cause dust or splashing.

-Perforated plate and cleaner rings set.

They are used to keep a clean mesh during the production.

-Ultrasonic sieve.

It is used for fine sieving. The ultrasonic waves do not let the dirt stays on the mesh, so the productivity is greater than a system with no ultrasonic sieve.

-Variable frequency drive.

It is used for a immediate sieving regulation. It is not necessary to make adjusts in the sieve shaker.