



GRINDING MILL



The grinding mill is used to mill fragile, soft and crystallized products. It is made in stainless steel (AISI 304 or AISI 316) and its surface is rilsanized and polished.

This grinding mill is designed to work with different interchangeable filters with circular perforations (diameters 2, 3, 4 and 5 mm.). This filters are a great advantage because the preparation time of the machine is minimum

Available models: **FML-0100**

TECHNICAL CHARACTERISTICS				
FML-0100	220-240 V 50-60 Hz	0.7 kW	5.4 A	3000 rpm.



Grinding mill with interchangeable filter.

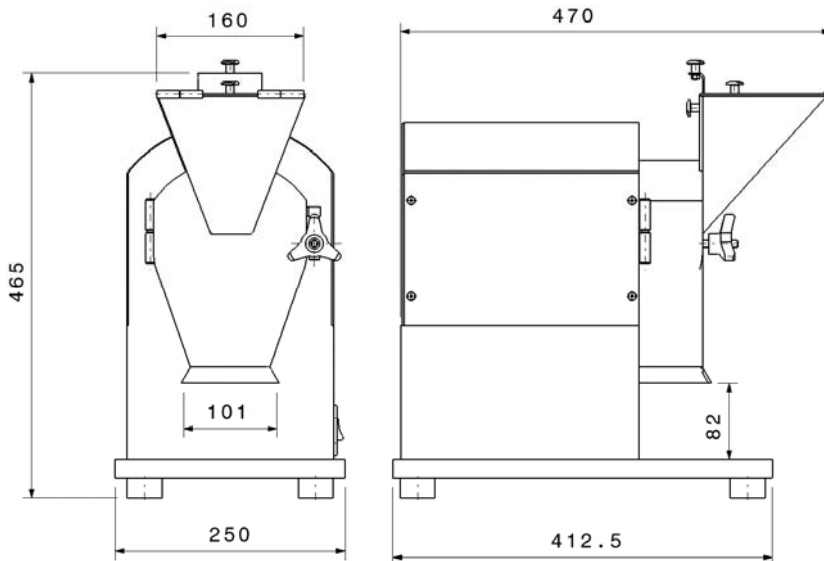

INCLUDE:

- ▶ Grinding mill.
- ▶ 1 interchangeable filter.
- ▶ Line power cord.
- ▶ Small recipient.
- ▶ Operating instructions manual.
- ▶ CE declaration of conformity.
- ▶ Packing.